

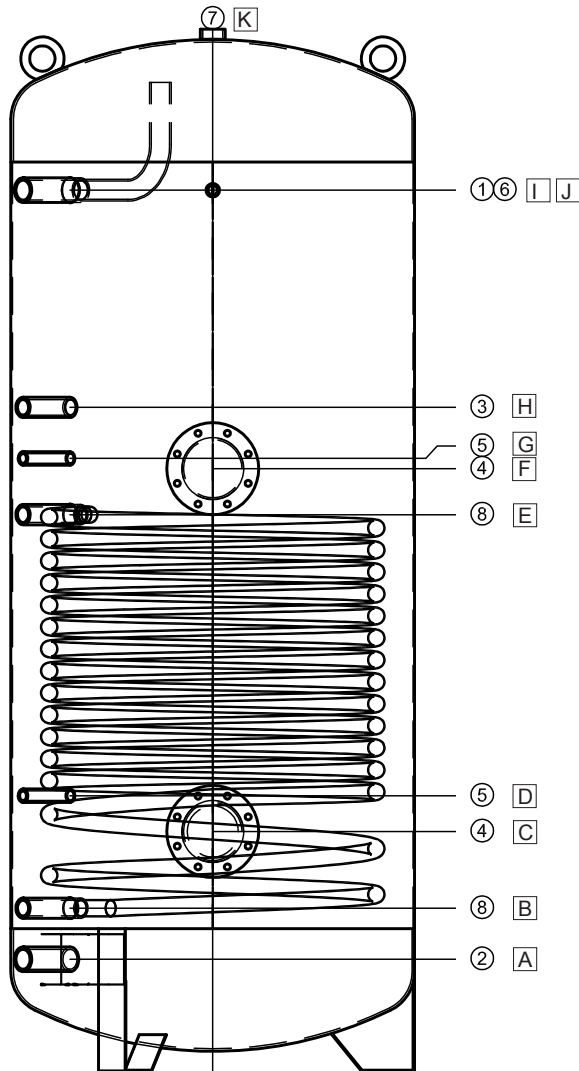

ARB HAUSTECHNIK GMBH
ERNEUERBARE ENERGIESYSTEME

EWS1 Datenblatt



- 1.) WW Muffe mit Steigrohr
- 2.) KW Muffe mit Schicht-U
- 3.) Zirkulation Muffe
- 4.) Flansch mit Deckel, Dichtung und Schrauben
- 5.) Muffe für Fühler
- 6.) Muffe für Thermometer
- 7.) Muffe für Anode
- 8.) Glattröhrwärmetauscher

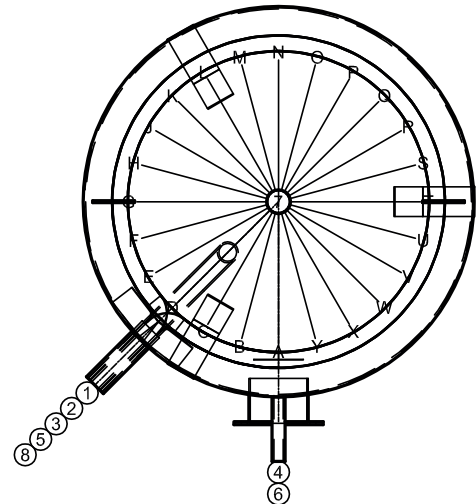

Isolation: - Type 300 – 600: 75 mm fix geschäumt mit Skai-Mantel silbergrau (Deckel 100 mm)
 - Type 750 – 1000: 130 mm Polyesterfaservlies mit Polystyrol-Mantel silbergrau (Deckel 150 mm)
 - Type 1500 – 2000: 160 mm Polyesterfaservlies mit Polystyrol-Mantel silbergrau (Deckel 200 mm)

Type	EWS1/300	EWS1/400	EWS1/500	EWS1/600	EWS1/750	EWS1/1000	EWS1/1250	EWS1/1500	EWS1/2000
Inhalt	300,0 l	414,2 l	499,8 l	577,9 l	791,7 l	900,0 l	1232,0	1430,0 l	1995,1 l
Ø	500	600	600	650	790	790	900	1000	1100
Ø ges.	650	750	750	790	1050	1050	1160	1320	1420
Höhe	-	-	-	-	1770	2020	2140	2050	2350
Höhe ges.	1870	1700	1960	2020	1900	2150	2270	2210	2510
Kippmass	1980	1860	2099	2170	1806	2052	2155	2088	2394
e.NLV ⁽¹⁾	137	187	218	272	392	412	483	620	979
Flansch	2 x Ø 120/180	2 x Ø 120/180	2 x Ø 120/180	2 x Ø 120/180	2 x Ø 120/180	2 x Ø 120/180	1 x Ø 170/240 1 x Ø 120/180	1 x Ø 170/240 1 x Ø 120/180	1 x Ø 220/290 1 x Ø 120/180
GWT	1,6 m ²	1,9 m ²	2,2 m ²	2,5 m ²	2,7 m ²	3,5 m ²	2,8 m ²	3,6 m ²	4,3 m ²
EU-WHV ⁽²⁾	63,3 W B	69,1 W B	75,9 W B	91,2 W	131,8 W	103,3 W	120,1 W	122,5 W	129,6 W
CH-WV ⁽³⁾	1,5 kWh/24h	1,7 kWh/24h	1,8 kWh/24h	2,2 kWh/24h	3,2 kWh/24h	2,5 kWh/24h	2,9 kWh/24h	2,9 kWh/24h	3,1 kWh/24h
Gewicht	95 kg	107 kg	153 kg	156 kg	192 kg	230 kg	270 kg	322 kg	485 kg

8 Energieeffizienzklasse ⁽¹⁾ elektrisches Nachladevolumen ^(2/3) Warmhalteverlust in W/h (EU) bzw. Wärmeverlust in kWh/24h (CH)

Anschlussdetails (Höhe in mm ab Unterkante Stehring bzw. Stellfüsse / Durchmesser Anschlüsse in Zoll)

Type	EWS1/300		EWS1/400		EWS1/500		EWS1/600		EWS1/750		EWS1/1000		EWS1/1250		EWS1/1500		EWS1/2000	
A	67	1"	80	1"	80	1"	280	1¼"	220	1¼"	220	1¼"	180	1½"	315	1½"	260	1½"
B	230	1"	220	1"	220	1"	360	1"	315	1¼"	320	1"	290	1"	435	1"	400	1"
C	360		325		325		450		435		470		480		575		580	
D	400	ø15 mm	360	ø15 mm	360	ø15 mm	450	ø15 mm	515	½"	540	½"	480	½"	665	½"	650	½"
E	1000	1"	850	1"	990	1"	1000	1"	855	1¼"	1090	1"	980	1"	1185	1"	1220	1"
F	1070		940		1090		1100		970		1180		1380		1260		1320	
G	870	ø15 mm	740	ø15 mm	810	ø15 mm	1340	¾"	1210	½"	1200	½"	1380	½"	1355	½"	1400	½"
H	1180	¾"	1110	¾"	1270	¾"	1680	1¼"	1260	1"	1300	1"	1510	1"	1450	1"	1520	1"
I	1530	½"	1385	½"	1650	½"	1680	½"	1460	½"	1725	½"	1860	½"	1690	½"	1990	½"
J	1723	1"	1540	1"	1800	1"	1920	1¼"	1470	1¼"	1725	1¼"	1860	1½"	1690	1½"	1990	1½"
K	1770	1¼"	1600	1¼"	1860	1¼"	1920	1¼"	1770	1½"	2020	1¼"	1710	1¼"	2050	1¼"	2350	1¼"

Leistungsdaten Glattrohrwärmetauscher

Register	80/60 °C 10/45 °C			Druck- verlust	80/60 °C 10/55 °C			Druck- verlust	80/60 °C 10/60 °C			Druck- verlust
	m²	KW	Liter		kPa	KW	Liter		kPa	KW	Liter	
1,6	43	1.056	3,6	37	707	2,9	33	567	2,3			
1,9	52	1.277	5,9	45	860	4,8	40	688	3,9			
2,2	65	1.597	10,8	53	1.012	7,4	47	808	5,9			
2,5	73	1.793	14,9	61	1.165	10,8	55	946	9,1			
2,7	80	1.965	19,1	67	1.280	13,9	59	1.014	10,9			
2,8	98	2.432	29,2	83	1.586	21,2	73	1.255	16,6			
3,5	105	2.580	40,3	88	1.681	29,2	79	1.359	24,2			
3,6	109	2.678	44,7	91	1.739	32,1	81	1.393	25,9			
4,3	131	3.218	74,2	110	2.100	54,0	99	1.702	44,9			

Register	70/50 °C 10/45 °C			Druck- verlust	70/50 °C 10/55 °C			Druck- verlust
	m²	KW	Liter		kPa	KW	Liter	
1,6	29	712	1,9	22	420	1,2		
1,9	36	884	3,4	27	516	2,0		
2,2	42	1.032	5,1	32	611	3,1		
2,5	49	1.204	7,6	37	707	4,6		
2,7	53	1.302	9,4	40	764	5,7		
2,8	65	1.597	14,1	49	937	8,5		
3,5	71	1.744	20,7	54	1.032	12,7		
3,6	73	1.793	22,3	56	1.070	14,0		
4,3	89	2.186	38,4	68	1.299	23,7		